



Tank Bottom Valve, pneumatically operated

- Fully integrated in Bürkert's Process Control Systems
- Monoblock – no welds
- Quality certifications /

Type 2033 can be combined with...



Type 1062

Electrical position feedback



Stroke limitation

Min./max. stroke limitation

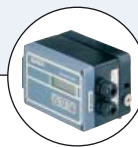

Type 1067

SideControl Positioner



Type 8630

Positioner Top-Control continuous



Type 8631

On/Off Control Head



Type 6012

Solenoid banjo valve

The Bürkert Tank Bottom Valve system is designed for control of ultra pure, sterile, aggressive or abrasive fluids. Enables especially optimal filling and emptying vessels with less dead leg.

The valve body consists of a block with no weld seam, machined out of high quality stainless steel. The Tank Bottom Valve has two welding bevels to ease the welding and valve positioning operations.

The high quality diaphragms separate hermetically critical fluids from the actuator. The pneumatic actuator can be controlled by pneumatic pilot valves (single pilot valves, valve islands and control heads). Control function A, normally closed by spring return.

Technical data			
Orifice	DN 8-100		
Body materials	Stainless steel 1.4435BN2 / ASME BPE Fe < 0.5% / C ≤ 0.03%		
Diaphragm materials	EPDM, PTFE/EPDM		
Actuator materials	PPS (PA on request)		
Pilot air ports	Stainless steel 1.4305		
Surface finish	Ra [µm]	Ra [µlnch]	Ra [Grit #]
	internal	internal	internal
satin finished	0.5	20	240
electro polished	0.4	16	280
mirror finished ¹⁾	0.25	10	330
Media temperature	-10° to +130°C (briefly up to +150°C)		
Ambient temperature	Actuator size < 100 mm Actuator size ≥ 100 mm		
	+5° to +140°C +5° to +90°C (briefly up to +140°C) (-10° to +60°C with PA actuator)		
Control media	Neutral gases; air		
Pilot pressure max.	max. 7 bar, see table on p. 2		
Port connections			
Weld end acc. to	<ul style="list-style-type: none"> ▪ EN ISO 1127 / ISO 4200 ▪ DIN 11850 Series 0 to 3 ▪ SMS 3008 ▪ ASME BPE ▪ BS 4825 		
Clamp acc. to	<ul style="list-style-type: none"> ▪ ISO 2852 - SMS 3017 ▪ ASME BPE ▪ DIN 32676 		

¹⁾Internal Ra < 0.1 µm/4 µlnch/500 Grit: on request

Technical data, continued

Orifice DN diaphragm [mm]	Actuator size Ø [mm]	Kv-value water [m³/h]	Pilot pressure [bar]	Max. operating pressure (medium) for seal material	
				EPDM [bar]	PTFE/ EPDM [bar]
8	40	1.0	5.0-7	10	10
15	50	4.0	5.0-7	8.5	5
	63	4.5	5.0-7	10	10
20	63	7.0	5.5-7	10	5
	80	7.5	5.0-7	10	10
25	80	12.0	5.5-7	10	7.5
40	100	30.0	5.5-7	6.5	6
	125	30.5	5.5-7	10	10
50	125	51.5	5.5-7	8	7
80	175	160.0	5.0-7	3	2
	225	160.0	5.0-7	6	5
100	225	235.0	5.0-7	4	2

Approvals/certifications

- Certification of Conformity for Raw Material EN-ISO 10204 3.1
- Attestation of compliance with the order EN-ISO 10204 2.1
- Test report EN-ISO 10204 2.2
- 3A Certification
- Certification of Conformity for Pickling and Electropolishing Processes
- Certification of Conformity for the Surface Quality DIN4762-DIN4768-ISO/4287/1
- Certification of Conformity for the 100% Weld inspection of Endoscopy RCCM RSEM ASME
- Attestation of compliance with FDA CFR No. 21.177.1550 for PTFE/EPDM and TFM/EPDM and 21.177.2600 for EPDM
- USP CLASS VI certification for EPDM and PTFE diaphragm
- Test Certification and Conformity Certification for the Final Assembly of Diaphragm Valves
- ISO 9001 Certification

Note: Retrospective manufacturing certification for process diaphragm valves can not be made, therefore please notify when ordering.

Materials

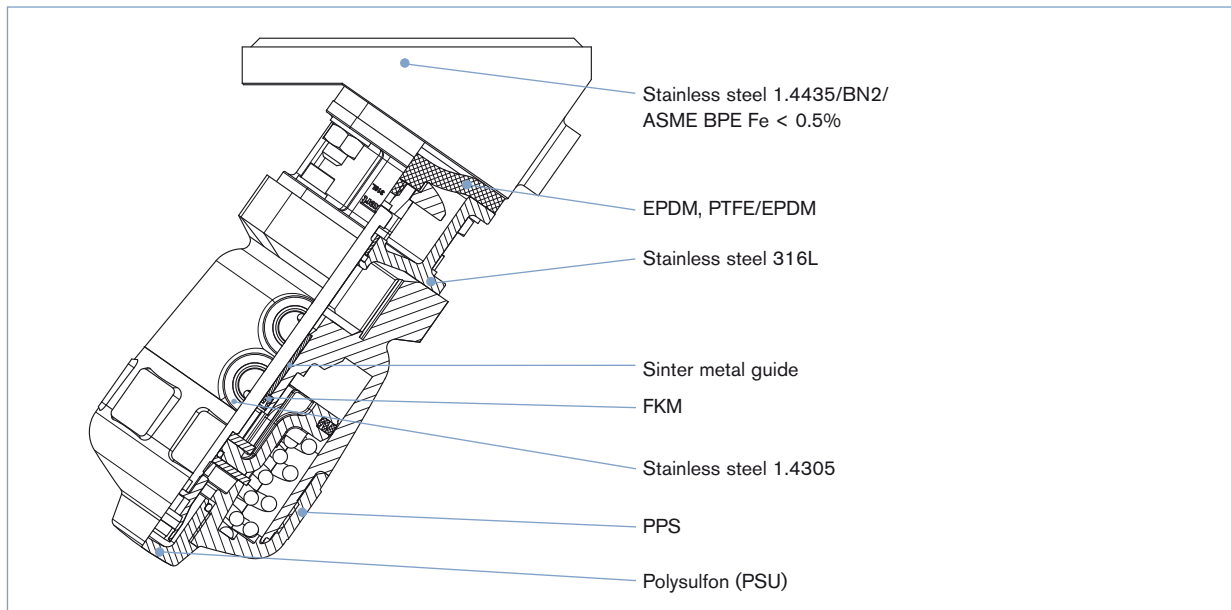

Example of available diaphragm materials

Developed to handle the unique challenges of hygienic and sterile applications, Bürkert offers diaphragms with precise material formula and physical tolerances. Bürkert diaphragms are available in a wide range of materials which have been proven in food & beverage, biotechnology, pharmaceutical and cosmetic industry applications. Diaphragms are tested during development and production to ensure reliability in critical processing environments.

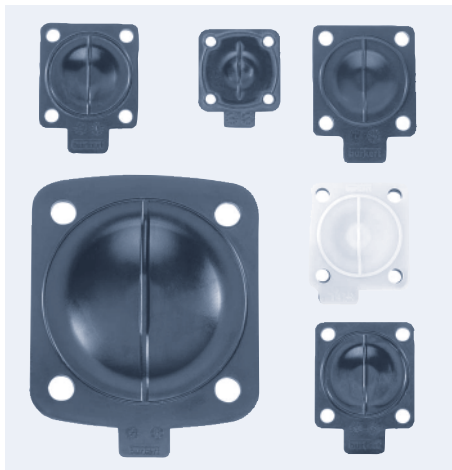

- EPDM (Ethylene Propylene Rubber)
- PTFE/EPDM
- TFM/EPDM
- FKM
- PTFE/FKM
- NBR

Dimensions [mm]

Body with weld end

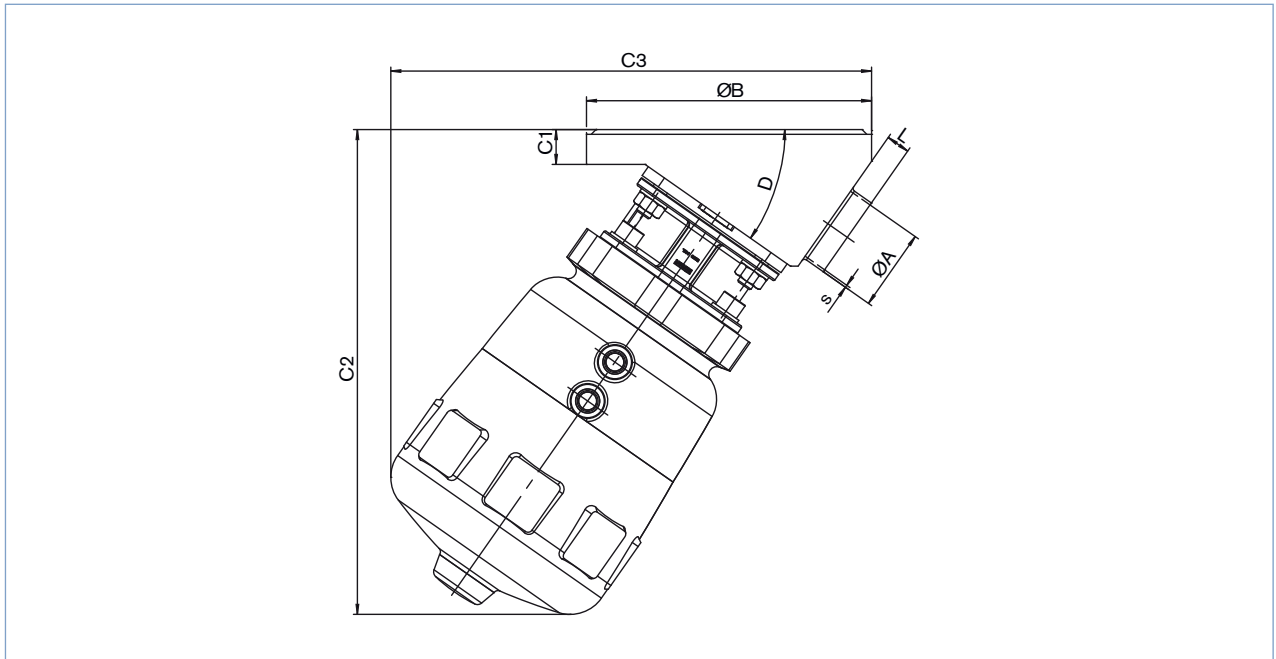

EN ISO 1127 / ISO 4200

Orifice seat [mm]	Port connection [mm]	Actuator size [mm]	øA	s	øB	C1	C2	C3	D	L
08	08	40	13.5	1.6	50	8	107	100	35°	5
15	15	50	21.3	1.6	65	12	146	134	35°	8
		63		85	160		147			
20	20	63	26.9	1.6	85	12	171	160	35°	5.6
		80			190		179			
25	25	80	33.7	2	120	16	183	174	35°	8
		100			200		192			
40	32	100	42.4	2	150	18	258	260	35°	15
	40	100	48.3	2			258	260	35°	15
		125					293	291		
50	50	125	60.3	2	180	22	306	304	35°	15
80	65	175	76.1	2	225	20	388	422	40°	15
	80		88.9	2.3			388	422		10
100	100	225	114.3	2.3	298	30	436	481	40°	11

ASME BPE

Orifice seat [mm]	Port connection [mm]	Actuator size [mm]	øA	s	øB	C1	C2	C3	D	L
08	08	40	6.35	0.89	50	8	107	100	35°	6
15	15	50	12.7	1.65	85	12	146	134	35°	10
		63		160			147			
20	20	63	19.05	1.65	85	12	171	160	35°	8
		80					190	179		
25	25	63	25.4	1.65	120	16	183	174	35°	8
		80					200	192		
40	40	100	38.1	1.65	150	18	258	260	35°	15
		125					293	291		
50	40	125	38.1	1.65	180	22	306	304	35°	25
	50	125	50.8	1.65						15
	65	125	63.5	1.65						11
80	80	175	76.2	1.65	225	20	388	422	40°	16
100	100	225	101.6	2.11	298	30	436	481	40°	16

Dimensions [mm], continued

Body with weld end, continued

DIN 11850 / RG2

Orifice seat [mm]	Port connection [mm]	Actuator size [mm]	øA	s	øB	C1	C2	C3	D	L
08	10	40	13	1.5	50	8	107	100	35°	6
15	15	50	19	1.5	85	12	146	134	35°	8
		63					160	147		
20	20	63	23	1.5	85	12	171	160	35°	7
		80					190	179		
25	25	63	29	1.5	120	16	183	174	35°	8
		80					200	192		
40	40	100	41	1.5	150	18	258	260	35°	15
		125					293	291		
50	50	125	53	1.5	180	22	306	304	35°	15
80	80	175	85	2.0	225	20	388	422	40°	15
100	100	225	104	2	298	30	436	481	40°	15

Dimensions [mm], continued

Clamp body

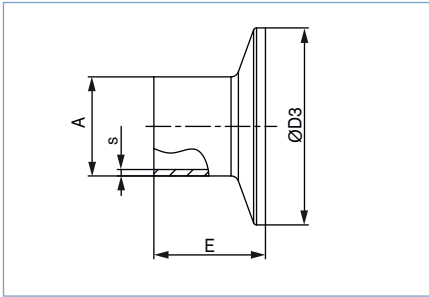

ASME BPE

Orifice		A	s	D3	E
[mm]	[inch]				
08	1/4"	6.35	0.89	25.0	28.6
10	3/8"	9.53	0.89	25.0	28.6
15	1/2"	12.7	1.65	25.0	28.6
20	3/4"	19.05	1.65	25.0	28.6
25	1"	25.4	1.65	50.5	28.6
40	1 1/2"	38.1	1.65	50.5	28.6
50	2"	50.8	1.65	64.0	28.6
65	2 1/2"	63.5	1.65	77.5	28.6
80	3"	76.2	1.65	91.0	28.6
100	4"	101.6	2.11	119.0	28.6

DIN 32676

Orifice [mm]	A	s	D3	E
10	1.5	34.0	18	18
15	19	1.5	34.0	18
20	23	1.5	34.0	18
25	29	1.5	50.5	21.5
32	35	1.5	50.5	21.5
40	41	1.5	50.5	21.5
50	53	1.5	64.0	21.5
65	70	2.0	91.0	28

ISO 2852 for pipe ISO 4200

Orifice [mm]	A	s	D3	E
8	13.5	1.6	25.0	28.6
8	13.5	1.6	34.0	28.6
10	17.2	1.6	34.0	28.6
15	21.3	1.6	34.0	28.6
15	21.3	1.6	50.5	28.6
20	26.9	1.6	50.5	28.6
25	33.7	2	50.5	28.6
32	42.4	2	50.5	28.6
40	48.3	2	64.0	28.6
50	60.3	2	77.5	28.6
65	76.1	2	91.0	28.6
100	114.3	2.3	130.0	28.6

SMS

Orifice [mm]	A	s	D3	E
25	25	1.2	50.5	21.5
40	38	1.2	50.5	28.6
50	51	1.2	64.0	28.6

Valve features

Example

A 15 AB B VI F085 SA42 D D NO09 + NO17 + AF71

Specification key

Please make a choice

CONTROL FUNCTION

A	normally closed by spring action
B	normally open by spring action
I	double acting

ORIFICE [mm] (diaphragm)

08
15
20
25
40
50
80
100

DIAPHRAGM MATERIAL

AB	EPDM in food quality
EA	PTFE
FF	FKM

PRODUCTION OF BODY

B	Monoblock
---	-----------

BODY MATERIAL

VH	1.4435/AISI 316L
VI	1.4435BN2/ASME BPE

standard

TANK FLANGE

F050	DN08 (Ø 50 mm)
F085	DN15 (Ø 85 mm)
F085	DN20 (Ø 85 mm)
F120	DN25 (Ø 120 mm)
F150	DN40 (Ø 150 mm)
F180	DN50 (Ø 180 mm)
F225	DN80 (Ø 225 mm)
F300	DN100 (Ø 298 mm)

VARIABLE CODES

Surface finish, external

NO03	Ext. Mirror finished Ra=0.25 µm
NO09	Ext. Electro polished Ra=3.2 µm
NO15	Ext. Electro polished Ra=0.8 µm
NO19	Ext. Mech. polished Ra=1.6 µm
NO22	Ext. Glassbeaded Ra= 3.2 µm

standard

Surface finish, internal

NO07	Int. Mirror finished Ra=0.25 µm
NO14	Int. Satin finished Ra=0.5 µm
NO17	Int. Electro finished Ra=0.4 µm
NO20	Int. Electro polished Ra=0.25 µm

standard

Specific angle

AF71	45° outlet angle
------	------------------

ACTUATOR SIZE 1)

C	ø 40 mm
D	ø 50 mm
E	ø 63 mm
F	ø 80 mm
G	ø 100 mm
H	ø 125 mm
K	ø 175 mm
L	ø 225 mm

1) for technical spec. see table, page 2

ACTUATOR MATERIAL

C	PA (for actuator sizes ø175/225 mm)
D	PPS



Port connection

Port connection weld end

Ori- fice DN [mm]	EN ISO 1127/ISO 4200	SMS 3008	DIN 11850				BS 4825	ASME BPE	JIS Sanitary	JIS Utility
			Series 0	Series 1	Series 2	Series 3				
08	SA40=13.5x1.6		SC42=10x1.0				SODB=6.35x1.2	SA90=6.35x0.89	SA70=13.8x1.65	
15	SA42=21.3x1.6		SC43=18x1.5	SF41=18x1.0	SD42=19x1.5	SE42=20x2.0	SODD=12.7x1.2	SA92=12.7x1.65	SA72=21.7x2.1	
20	SA43=26.9x1.6		SC44=22x1.5	SF42=22x1.0	SD43=23x1.5	SE43=24x2.0	SODE=19.05x1.2	SA93=19.05x1.65	SA76=27.2x2.1	SA80=27.2x2.1
25	SA44=33.7x2.0	SA60=25.0x1.2	SC45=28x1.5	SF43=28x1.0	SD44=29x1.5	SE44=30x2.0	SODF=25.4x1.65	SODF=25.4x1.65	SA73=25.4x1.2	SA81=34x2.0
32	SA45=42.4x2.0		SC46=34x1.5	SF44=34x1.0	SD45=35x1.5	SE45=36x2.0				SA83=42.7x2.0
40	SA46=48.3x2.0	SA62=38.0x1.2	SC47=40x1.5	SF45=40x1.0	SD46=41x1.5	SE46=42x2.0	SODH=38.1x1.65	SODH=38.1x1.65	SA74=38.1x1.2	SA83=48.6x2.0
50	SA47=60.3x2.0	SA63=51.0x1.2	SC48=52x1.5	SF46=52x1.0	SD47=53x1.5	SE47=54x2.0	SODI=50.8x1.65	SODI=50.8x1.65	SA75=50.8x1.5	SA84=60.5x2.0
65	SA48=76.1x2.0	SA64=63.5x1.6			SD48=70x2.0		SA64=63.5x1.65	SA64=63.5x1.65		
80	SA49=88.9x2.3	SA65=76.1x1.6			SD49=85x2.0		SA65=76.2x1.65	SA65=76.2x1.65		
100	SA39=114.3x2.3	SA66=101.6x2.0			SD50=104x2.0		SA66=101.6x2.11	SA66=101.6x2.11		

Port connection clamp

Orifice DN [mm]	ISO 2852 SMS 3017	ASME BPE	DIN 32676
8	TC51=Clamp 34 - for tube ISO 4200	TG50=Clamp 25 - Tube 6.35x0.89	
10	TC41=Clamp 34 - for tube ISO 4200	TG01=Clamp 25 - Tube 9.53x0.89	TD41=Clamp 34 - Tube 13x1.5
15	TC42=Clamp 34 - for tube ISO 4200	TG02=Clamp 25 - Tube 12.7x1.65	TD42=Clamp 34 - Tube 19x1.5
20	TC43=Clamp 50.5 - for tube ISO 4200	TG03=Clamp 25 - Tube 19.05x1.65	TD43=Clamp 34 - Tube 23x1.5
25	TC44=Clamp 50.5 - for tube ISO 4200	TG04=Clamp 50.5 - Tube 25.4x1.65	TD44=Clamp 50.5 - Tube 29x1.5
40	TC46=Clamp 64 - for tube ISO 4200	TG05=Clamp 50.5 - Tube 38.1x1.65	TD46=Clamp 50.5 - Tube 41x1.5
50	TC47=Clamp 77.5 - for tube ISO 4200	TG06=Clamp 64 - Tube 50.8x1.65	TD47=Clamp 64 - Tube 53x1.5
65	TC48=Clamp 91 - for tube ISO 4200	TG07=Clamp 77.5 - Tube 63.5x1.65	TD48=Clamp 91 - Tube 70x2
80	-		-
100	TC50=Clamp 130 - for tube ISO 4200	TG09=Clamp 119 - Tube 101.6x2.11	-

In case of special application conditions, please consult for advice.

Subject to alteration.
© Christian Bürkert GmbH & Co. KG

0902/7_EU-en_00891853