



2/2-way Angle-Seat Valve with stainless steel design for media up to +180°C, DN 13-50

- High flow rates
- High cycle life
- Flow optimised body in stainless steel
- Deliverable with flow direction below or above seat
- Clean design for optimal use in hygienic environment

Type 2100 can be combined with...



Type 8690

Pneum. control unit with feedback



Type 8691

Control head



Type 8695

Control head



Type 8645

Automation system FreeLINE



Type 8222

Conductivity transmitter

In line with Bürkert's philosophy for modular valves and sensors the construction of the 2100 angle-seat valve fulfils tough criteria for process environments. Unrivalled cycle life and sealing integrity is guaranteed by the proven self adjusting packing gland.

The design enables the easy integration of automation modules whether they are electrical/optical position feedback, pneumatic control units, an integrated fieldbus interface or even an explosion proof feedback.

The fully integrated system has a compact and smooth design, integrated pneumatic lines, IP65/67/NEMA4X protection class and superior chemical resistance.

Technical data	
Orifice	DN 13 to 50
Port connections	G 1/2 to G 2, NPT 1/2 to NPT 2, Rc 1/2 to Rc 2 EN ISO 1127, DIN 11850 S2, ASME BPE, SMS 3008, BS 4825 ISO 2852, ASME BPE
Threaded port acc. to Welded acc. to	
Clamp acc. to	
Body material	Casted stainless steel 316L
Threaded port body	
Welded body	Stainless steel 1.4581 (316L on request)
-EN ISO 1127/ISO 4200 and DIN 11850 Serie 2	
-ASME BPE, SMS 3008, BS 4825 Part 1	
Clamp body	Stainless steel 316L Stainless steel 316L
Actuator material	
Actuator	PPS
Cover	Stainless steel 1.4561 (316Ti)
Sealing material	PTFE
Media	Water, alcohol, oils, fuels, hydraulic fluids, salt solution, alkali solutions, organic solvents, steam
Viscosity	max. 600 mm ² /s
Packing gland	PTFE V-rings with spring compensation
Media temperature	-10 to +180 °C
Ambient temperature	0 to +60 °C
Control medium	Neutral gases, air
Max. pilot pressure	max. 10 bar
Pilot air ports	Push-in connector for ø 6/4 mm hose, thread G1/8 (on request)
Installation	As required, preferably with actuator in upright position

Content

Valve specifications	System specifications On/Off	Request for quotation
Type 2100	Type 8801-YE	Type 8801-YE
Technical data & ordering info. p. 1-15	Ordering info. & technical data p. 16-21	p. 22

Technical data angle seat valve Type 2100 flow direction below the seat (for gases and liquids)

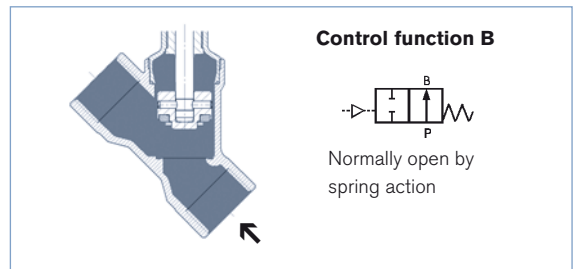
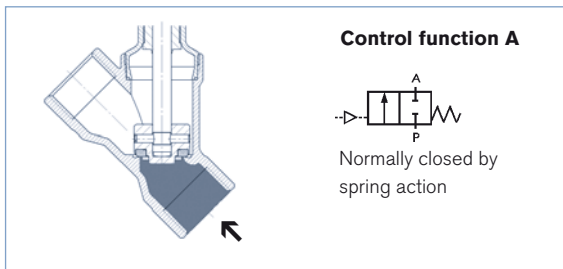

Orifice [mm]	Actuator size [mm]	Kv value water (m³/h)	Minimum pilot pressure SFA [bar]	Operating pressure up to +180°	
				SFA [bar]	SFB [bar]
13	50	4.2	5.0	25	16
	70	4.2	5.0	25	16
20	70	10	5.0	20	16
25	70	20	5.0	16	16
32	70	28	5.0	8.5	16
	90	30	5.0	16	16
40	70	38	5.0	6	16
	90	40	5.0	16	16
50	70	52	-	-	16
	90	53	5.0	10	16

Flow rate: Kv value water [m³/h]; Measured at +20 °C, 1 bar pressure at valve inlet and free outlet.

Pressure valves [bar]: Overpressure to the atmospheric pressure

Pressure charts with control function B and flow direction below the seat

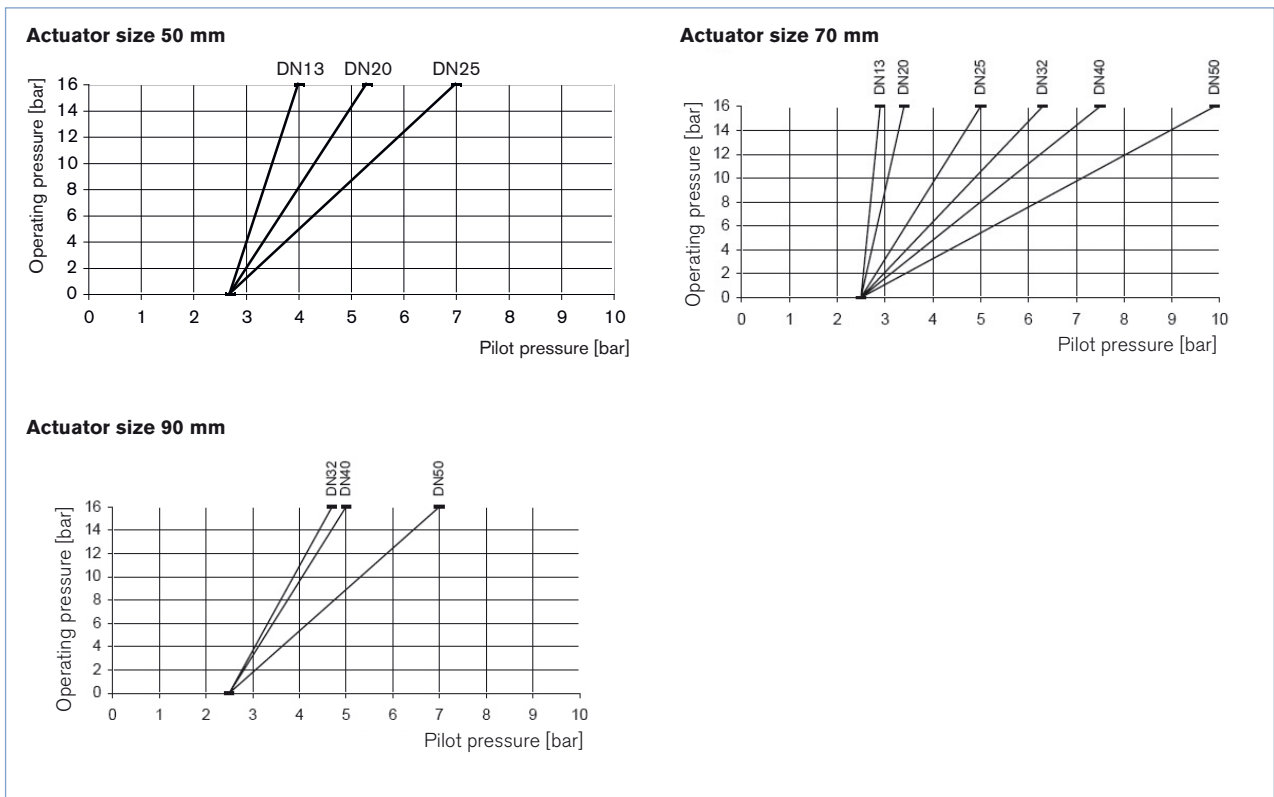

Ordering chart Type 2100, flow direction below the seat (for gases and liquids)

G threaded port, flow direction below the seat

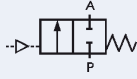
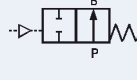
Control function	Orifice [mm]	Actuator size ϕ [mm]	Port connection threaded port	Minimum pilot pressure [bar]	Operating pressure up to +180 °C [bar]	Item no.	
A 2/2-way valve, NC 	13	50	G 1/2	5.0	25	187 040	
		70	G 1/2	5.0	25	175 099	
	20	70	G 3/4	5.0	20	175 101	
		25	70	G 1	5.0	16	175 102
		32	70	G 1 1/4	5.0	8.5	175 104
			90	G 1 1/4	5.0	16	175 105
		40	70	G 1 1/2	5.0	6	175 106
			90	G 1 1/2	5.0	16	175 107
50	90	G 2	5.0	10	175 108		
B 2/2-way valve, NO 	13	50	G 1/2	see chart on p. 2	16	187 045	
		70	G 1/2		16	175 117	
	20	50	G 3/4		16	187 046	
		70	G 3/4		16	175 119	
	25	70	G 1		16	175 120	
	32	70	G 1 1/4		16	175 121	
	40	70	G 1 1/2		16	175 122	
	50	70	G 2		16	175 123	

NPT threaded port, flow direction below the seat

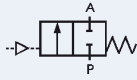
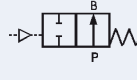
Control function	Orifice (mm)	Actuator size ϕ [mm]	Port connection threaded port	Minimum pilot pressure [bar]	Operating pressure up to +180 °C [bar]	Item no.
A 2/2-way valve, NC 	13	50	NPT 1/2	5.0	25	187 053
		70	NPT 1/2	5.0	25	188 634
	20	70	NPT 3/4	5.0	20	188 635
		25	70	NPT 1	5.0	16
	32	70	NPT 1 1/4	5.0	8.5	188 637
		90	NPT 1 1/4	5.0	16	188 638
	40	70	NPT 1 1/2	5.0	6	188 639
		90	NPT 1 1/2	5.0	16	188 640
50	90	NPT 2	5.0	10	188 641	
B 2/2-way valve, NO 	13	50	NPT 1/2	see chart on p. 2	16	187 057
		70	NPT 1/2		16	188 651
	20	50	NPT 3/4		16	187 058
		70	NPT 3/4		16	188 652
	25	70	NPT 1		16	188 653
	32	70	NPT 1 1/4		16	188 654
	40	70	NPT 1 1/2		16	188 655
	50	70	NPT 2		16	188 656

i Further versions on request

 Control function
I (double-acting)

Ordering chart Type 2100, flow direction below the seat (for gases and liquids), *continued*

RC threaded port, flow direction below the seat

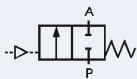
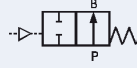
Control function	Orifice (mm)	Actuator size \varnothing [mm]	Port connection threaded port	Minimum pilot pressure [bar]	Operating pressure up to +180 °C [bar]	Item no.
A 2/2-way valve, NC 	13	50	RC 1/2	5.0	25	187 059
	13	70	RC 1/2	5.0	25	188 657
	20	70	RC 3/4	5.0	20	188 658
	25	70	RC 1	5.0	16	188 659
	32	70	RC 1 1/4	5.0	8.5	188 660
	32	90	RC 1 1/4	5.0	16	188 661
	40	70	RC 1 1/2	5.0	6	188 662
	40	90	RC 1 1/2	5.0	16	188 663
	50	90	RC 2	5.0	10	188 664
	B 2/2-way valve, NO 	13	50	RC 1/2	see chart on p. 2	16
13		70	RC 1/2	16		188 674
20		50	RC 3/4	16		187 064
20		70	RC 3/4	16		188 675
25		70	RC 1	16		188 676
32		70	RC 1 1/4	16		188 677
40		70	RC 1 1/2	16		188 678
50		70	RC 2	16		188 679

 Further versions on request

 Control function
I (double-acting)

Ordering chart Type 2100, flow direction below the seat (for gases and liquids), *continued*

Weld end acc. to EN ISO 1127, flow direction below the seat

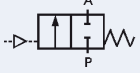
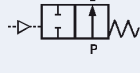
Control function	Orifice (mm)	Actuator size \varnothing [mm]	Port connection tube- \varnothing [mm]	Minimum pilot pressure [bar]	Operating pressure up to +180 °C [bar]	Item no.
A 2/2-way valve, NC 	15	50	21.3 x 1.6	5.0	25	187 065
	15	70	21.3 x 1.6	5.0	25	188 680
	20	70	26.9 x 1.6	5.0	20	188 681
	25	70	33.7 x 2	5.0	16	188 682
	32	70	42.4 x 2	5.0	8.5	188 683
	32	90	42.4 x 2	5.0	16	188 684
	40	70	48.3 x 2	5.0	6	188 685
	40	90	48.3 x 2	5.0	16	188 686
	50	90	60.3 x 2.6	5.0	10	188 687
B 2/2-way valve, NO 	15	50	21.3 x 1.6	see chart on p. 2	16	187 069
	15	70	21.3 x 1.6		16	188 697
	20	50	26.9 x 1.6		16	187 070
	20	70	26.9 x 1.6		16	188 698
	25	70	33.7 x 2		16	188 699
	32	70	42.4 x 2		16	188 700
	40	70	48.3 x 2		16	188 701
	40	90	48.3 x 2		16	188 702
	50	70	60.3 x 2.6		16	188 702

Weld end acc. to DIN 11850 S2, flow direction below the seat

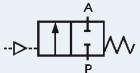
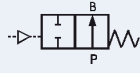
Control function	Orifice (mm)	Actuator size \varnothing [mm]	Port connection tube- \varnothing [mm]	Minimum pilot pressure [bar]	Operating pressure up to +180 °C [bar]	Item no.
A 2/2-way valve, NC 	15	50	19 x 1.5	5.0	25	187 071
	15	70	19 x 1.5	5.0	25	188 703
	20	70	23 x 1.5	5.0	20	188 704
	25	70	29 x 1.5	5.0	16	188 705
	32	70	35 x 1.5	5.0	8.5	188 706
	32	90	35 x 1.5	5.0	16	188 707
	40	70	41 x 1.5	5.0	6	188 708
	40	90	41 x 1.5	5.0	16	188 709
	50	90	53 x 1.5	5.0	10	188 710
B 2/2-way valve, NO 	15	50	19 x 1.5	see chart on p. 2	16	187 075
	15	70	19 x 1.5		16	188 720
	20	50	23 x 1.5		16	187 076
	20	70	23 x 1.5		16	188 721
	25	70	29 x 1.5		16	188 722
	32	70	35 x 1.5		16	188 723
	40	70	41 x 1.5		16	188 724
	40	90	41 x 1.5		16	188 724
	50	70	53 x 1.5		16	188 725

i Further versions on request
**Material**

Body: Stainless steel 316L

**Control function**

I (double-acting)

Ordering chart Type 2100, flow direction below the seat (for gases and liquids), *continued*

Weld end acc. to ASME BPE, flow direction below the seat

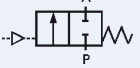
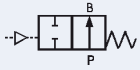
Control function	Orifice (mm)	Actuator size \varnothing [mm]	Port connection tube- \varnothing [mm]	Minimum pilot pressure [bar]	Operating pressure up to +180 °C [bar]	Item no.
A 2/2-way valve, NC 	15	50	12.7 x 1.65	5.0	25	187 077
	15	70	12.7 x 1.65	5.0	25	188 726
	20	70	19.05 x 1.65	5.0	20	188 727
	25	70	25.4 x 1.65	5.0	16	188 728
	40	70	38.1 x 1.65	5.0	6	188 729
	40	90	38.1 x 1.65	5.0	16	188 730
	50	90	50.8 x 1.65	5.0	10	188 731
B 2/2-way valve, NO 	15	50	12.7 x 1.65	see chart on p. 2	16	187 082
	15	70	12.7 x 1.65	see chart on p. 2	16	188 740
	20	50	19.05 x 1.65	see chart on p. 2	16	187 083
	20	70	19.05 x 1.65	see chart on p. 2	16	188 741
	25	70	25.4 x 1.65	see chart on p. 2	16	188 742
	40	70	38.1 x 1.65	see chart on p. 2	16	188 743
	50	70	50.8 x 1.65	see chart on p. 2	16	188 744

Weld end acc. to SMS 3008, flow direction below the seat

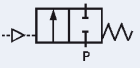
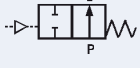
Control function	Orifice (mm)	Actuator size \varnothing [mm]	Port connection tube- \varnothing [mm]	Minimum pilot pressure [bar]	Operating pressure up to +180 °C [bar]	Item no.
A 2/2-way valve, NC 	15	50	12 x 1.0	5.0	25	187 084
	15	70	12 x 1.0	5.0	25	188 745
	20	70	18 x 1.0	5.0	20	188 746
	25	70	25 x 1.2	5.0	16	188 747
	40	70	38 x 1.2	5.0	6	188 748
	40	90	38 x 1.2	5.0	16	188 749
	50	90	51 x 1.2	5.0	10	188 750
B 2/2-way valve, NO 	15	50	12 x 1.0	see chart on p. 2	16	187 089
	15	70	12 x 1.0	see chart on p. 2	16	188 759
	20	50	18 x 1.0	see chart on p. 2	16	187 090
	20	70	18 x 1.0	see chart on p. 2	16	188 760
	25	70	25 x 1.2	see chart on p. 2	16	188 761
	40	70	38 x 1.2	see chart on p. 2	16	188 762
	50	70	51 x 1.2	see chart on p. 2	16	188 763

Weld end acc. to BS 4825, flow direction below the seat

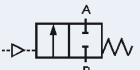
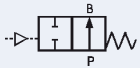
Control function	Orifice (mm)	Actuator size \varnothing [mm]	Port connection tube- \varnothing [mm]	Minimum pilot pressure [bar]	Operating pressure up to +180 °C [bar]	Item no.
A 2/2-way valve, NC 	15	50	12.7 x 1.2	5.0	25	187 091
	15	70	12.7 x 1.2	5.0	25	188 764
	20	70	19.05 x 1.65	5.0	20	188 765
	25	70	25.4 x 1.65	5.0	16	188 766
	40	70	38.1 x 1.65	5.0	6	188 767
	40	90	38.1 x 1.65	5.0	16	188 768
	50	90	50.8 x 1.65	5.0	10	188 769
B 2/2-way valve, NO 	15	50	12.7 x 1.2	see chart on p. 2	16	187 095
	15	70	12.7 x 1.2	see chart on p. 2	16	188 778
	20	50	19.05 x 1.65	see chart on p. 2	16	187 096
	20	70	19.05 x 1.65	see chart on p. 2	16	188 779
	25	70	25.4 x 1.65	see chart on p. 2	16	188 780
	40	70	38.1 x 1.65	see chart on p. 2	16	188 781
	50	70	50.8 x 1.65	see chart on p. 2	16	188 782

Ordering chart Type 2100, flow direction below the seat (for gases and liquids), *continued*

Clamp acc. to ISO 2852, flow direction below the seat

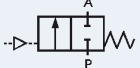
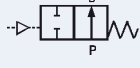
Control function	Orifice (mm)	Actuator size \varnothing [mm]	Port connection clamp external \varnothing (mm)	Minimum pilot pressure [bar]	Operating pressure up to +180 °C [bar]	Item no.
A 2/2-way valve, NC 	15	50	34.0	5.0	25	187 097
	15	70	34.0	5.0	25	188 783
	20	70	50.5	5.0	20	188 784
	25	70	50.5	5.0	16	188 785
	32	70	50.5	5.0	8.5	188 786
	32	90	50.5	5.0	16	188 787
	40	70	64.0	5.0	6	188 788
	40	90	64.0	5.0	16	188 789
	50	90	77.5	5.0	10	188 790
B 2/2-way valve, NO 	15	50	34.0	see chart on p. 2	16	187 101
	15	70	34.0		16	188 800
	20	50	50.5		16	187 102
	20	70	50.5		16	188 801
	25	70	50.5		16	188 802
	32	70	50.5		16	188 803
	40	70	64.0		16	188 804
	40	90	64.0		16	188 804
	50	70	77.5		16	188 805

Clamp acc. to ASME BPE, flow direction below the seat

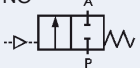
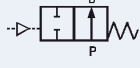
Control function	Orifice (mm)	Actuator size \varnothing [mm]	Port connection clamp external \varnothing (mm)	Minimum pilot pressure [bar]	Operating pressure up to +180 °C [bar]	Item no.
A 2/2-way valve, NC 	15	50	25.0	5.0	25	187 103
	15	70	25.0	5.0	25	188 806
	20	70	25.0	5.0	20	188 807
	25	70	50.5	5.0	16	188 808
	40	70	50.5	5.0	6	188 809
	40	90	50.5	5.0	16	188 810
	50	90	64.0	5.0	10	188 811
B 2/2-way valve, NO 	15	50	25.0	see chart on p. 2	16	187 107
	15	70	25.0		16	188 820
	20	50	25.0		16	187 108
	20	70	50.5		16	188 821
	25	70	50.5		16	188 822
	40	70	50.5		16	188 823
	50	70	64.0		16	188 824

i Further versions on request

Control function
 I (double-acting)

Technical data angle seat valve Type 2100 flow direction above the seat (for gases and steam)

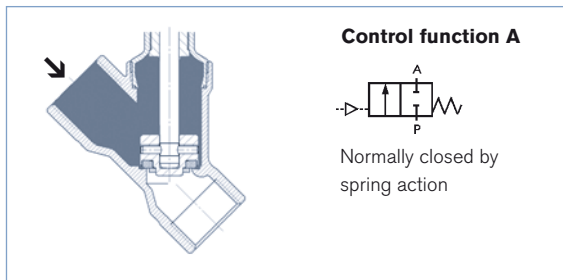

Attention!

Valves with flow above the seat are only conditionally usable for liquid media. There is a danger of waterhammer!

Orifice [mm]	Actuator size [mm]	Kv value water (m ³ /h)	Operating pressure up to +180° NC (A) [bar]
13	50	4.2	16
	70	4.2	16
20	50	10	16
	70	10	16
25	50	20	16
	70	20	16
32	70	28	16
40	70	38	16
	90	40	16
50	70	52	12
	90	53	16

Flow rate: Kv value water [m³/h]: Measured at +20 °C, 1 bar pressure at valve inlet and free outlet.

Pressure valves [bar]: Overpressure to the atmospheric pressure

Pressure charts with control function A and flow direction above the seat

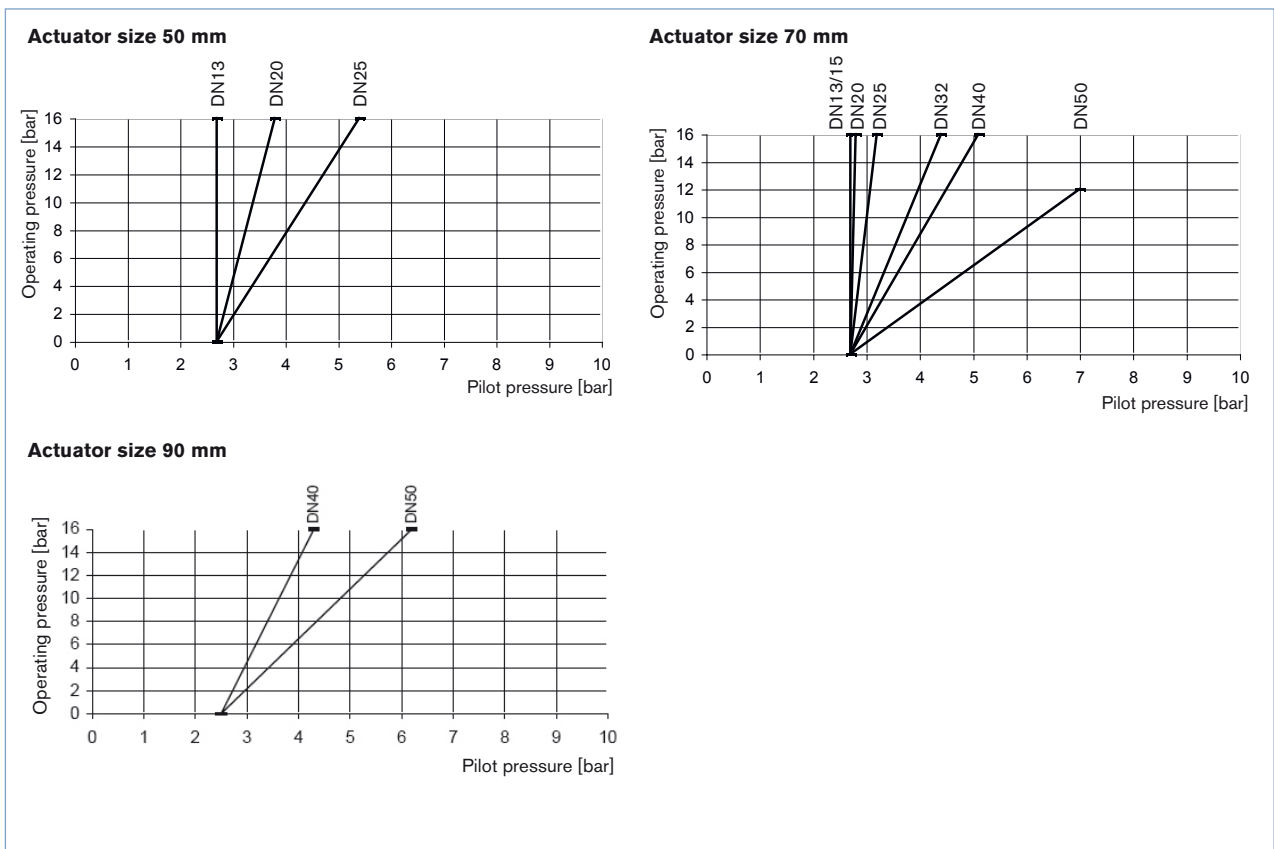

Ordering chart Type 2100 flow direction above the seat (for gases and steam)

G threaded port, flow direction above the seat

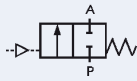
Control function	Orifice (mm)	Actuator size ø [mm]	Port connection threaded port	Minimum pilot pressure [bar]	Operating pressure up to +180 °C [bar]	Item no.
A 2/2-way valve, NC 	13	50	G 1/2	see chart on p. 8	16	187 041
		70	G 1/2		16	175 109
	20	50	G 3/4		16	187 043
		70	G 3/4		16	175 110
	25	50	G 1		16	187 044
		70	G 1		16	175 111
	32	70	G 1 1/4		16	175 112
	40	70	G 1 1/2		16	175 113
		90	G 1 1/2		16	175 114
	50	70	G 2		12	175 115
90		G 2	16	175 116		

NPT threaded port, flow direction above the seat

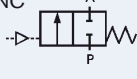
Control function	Orifice (mm)	Actuator size ø [mm]	Port connection threaded port	Minimum pilot pressure [bar]	Operating pressure up to +180 °C [bar]	Item no.	
A 2/2-way valve, NC 	13	50	NPT 1/2	see chart on p. 8	16	187 054	
		50	NPT 3/4		16	187 055	
		25	50		NPT 1	16	187 056
		32	70		NPT 1 1/4	16	188 646
		40	70		NPT 1 1/2	16	188 647
		50	70		NPT 2	12	188 649

RC threaded port, flow direction above the seat

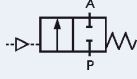
Control function	Orifice (mm)	Actuator size ø [mm]	Port connection threaded port	Minimum pilot pressure [bar]	Operating pressure up to +180 °C [bar]	Item no.	
A 2/2-way valve, NC 	13	50	RC 1/2	see chart on p. 8	16	187 060	
		50	RC 3/4		16	187 061	
		25	50		RC 1	16	187 062
		32	70		RC 1 1/4	16	188 669
		40	70		RC 1 1/2	16	188 670
		50	70		RC 2	12	188 672

Ordering chart Type 2100 flow direction above the seat (for gases and steam), *continued*

Weld end acc. to EN ISO 1127, flow direction above the seat

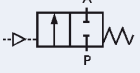
Control function	Orifice (mm)	Actuator size ϕ [mm]	Port connection tube- ϕ [mm]	Minimum pilot pressure [bar]	Operating pressure up to +180 °C [bar]	Item no.
A 2/2-way valve, NC 	15	50	21.3 x 1.6	see chart on p. 8	16	187 066
	20	50	26.9 x 1.6		16	187 067
	25	50	33.7 x 2		16	187 068
	32	70	42.4 x 2		16	188 692
	40	70	48.3 x 2		16	188 693
	50	70	60.3 x 2.6		12	188 695

Weld end acc. to DIN 11850 S2, flow direction above the seat

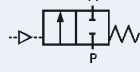
Control function	Orifice (mm)	Actuator size ϕ [mm]	Port connection tube- ϕ [mm]	Minimum pilot pressure [bar]	Operating pressure up to +180 °C [bar]	Item no.
A 2/2-way valve, NC 	15	50	19 x 1.5	see chart on p. 8	16	187 072
	20	50	23 x 1.5		16	187 073
	25	50	29 x 1.5		16	187 074
	32	70	35 x 1.5		16	188 715
	40	70	41 x 1.5		16	188 716
	50	70	53 x 1.5		12	188 718

 Further versions on request



Material

Body: Stainless steel 316L

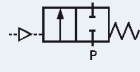
Weld end acc. to ASME BPE, flow direction above the seat

Control function	Orifice (mm)	Actuator size ϕ [mm]	Port connection tube- ϕ [mm]	Minimum pilot pressure [bar]	Operating pressure up to +180 °C [bar]	Item no.
A 2/2-way valve, NC 	15	50	12.7 x 1.65	see chart on p. 8	16	187 078
	20	50	19.05 x 1.65		16	187 079
	25	50	25.4 x 1.65		16	187 080
	40	70	38.1 x 1.65		16	188 736
	50	70	50.8 x 1.65		12	188 738

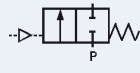
Weld end acc. to SMS 3008, flow direction above the seat

Control function	Orifice (mm)	Actuator size ϕ [mm]	Port connection tube- ϕ [mm]	Minimum pilot pressure [bar]	Operating pressure up to +180 °C [bar]	Item no.
A 2/2-way valve, NC 	15	50	12 x 1.0	see chart on p. 8	16	187 085
	20	50	18 x 1.0		16	187 086
	25	50	25 x 1.2		16	187 087
	40	70	38 x 1.2		16	188 755
	50	70	51 x 1.2		12	188 757

Ordering chart Type 2100 flow direction above the seat (for gases and steam), *continued*

Weld end acc. to BS 4825, flow direction above the seat

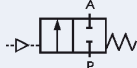
Control function	Orifice (mm)	Actuator size \varnothing [mm]	Port connection tube- \varnothing [mm]	Minimum pilot pressure [bar]	Operating pressure up to +180 °C [bar]	Item no.
A 2/2-way valve, NC 	15	50	12.7 x 1.2	see chart on p. 8	16	187 092
	20	50	19.05 x 1.65		16	187 093
	25	50	25.4 x 1.65		16	187 094
	40	70	38.1 x 1.65		16	188 774
	50	70	50.8 x 1.65		12	188 776

Clamp acc. to ISO 2852, flow direction above the seat

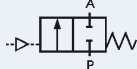
Control function	Orifice (mm)	Actuator size \varnothing [mm]	Port connection clamp external \varnothing (mm)	Minimum pilot pressure [bar]	Operating pressure up to +180 °C [bar]	Item no.
A 2/2-way valve, NC 	15	50	34.0	see chart on p. 8	16	187 098
	20	50	50.5		16	187 099
	25	50	50.5		16	187 100
	32	70	50.5		16	188 795
	40	70	64.0		16	188 796
	50	70	77.5		12	188 798

Clamp acc. to ASME BPE, flow direction above the seat

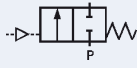
Control function	Orifice (mm)	Actuator size \varnothing [mm]	Port connection clamp external \varnothing (mm)	Minimum pilot pressure [bar]	Operating pressure up to +180 °C [bar]	Item no.
A 2/2-way valve, NC 	15	50	25.0	see chart on p. 8	16	187 104
	20	50	25.0		16	187 105
	25	50	50.5		16	187 106
	40	70	50.5		16	188 816
	50	70	64.0		12	188 818

Materials angle seat valve Type 2100

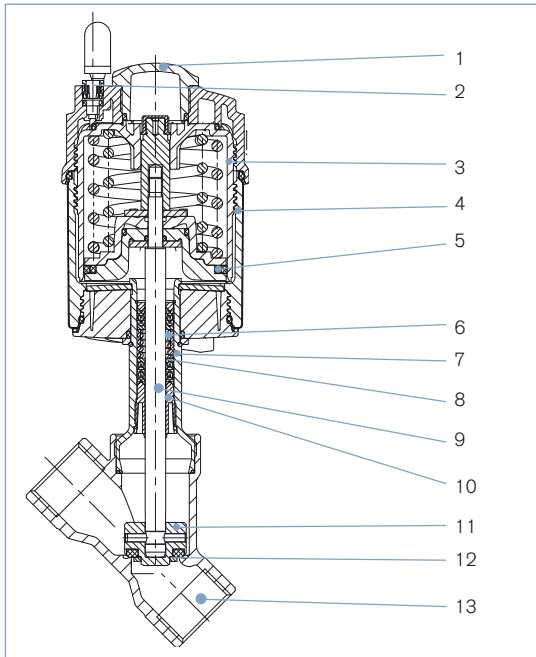

- 1 Optical position indicator** Transparent cap polysulfone PSU
- 2 Pilot air ports** Push-in connector PP (standard)
On request:
Thread G1/8" stainless steel 1.4305
- 3 Actuator** PPS
- 4 Cover** Stainless steel 1.4561 (316Ti)
- 5 Piston seal** FKM
- 6 Spring** Stainless steel 1.4310
- 7 Pipe** Stainless steel 1.4401 (316)
(1.4404 (316L) on request)
- 8 V-seals** PTFE
- 9 Spindle** Stainless steel 1.4401 (316)
(1.4404 (316L) on request)
- 10 Wiper** PEEK
- 11 Swivel plate** Stainless steel 1.4401 (316)
(1.4404 (316L) on request)
- 12 Seals** PTFE
- 13 Valve body**
Threaded body Casted stainless steel 316L
Welded body
-EN ISO 1127/ISO 4200 and
DIN 11850 S 2 Stainless steel 1.4581 (316L on request)
-ASME BPE, SMS 3008,
BS 4825 Part 1 Stainless steel 316L
Clamp body Stainless steel 316L

Dimensions angle seat valve Type 2100 [mm]

Threaded body

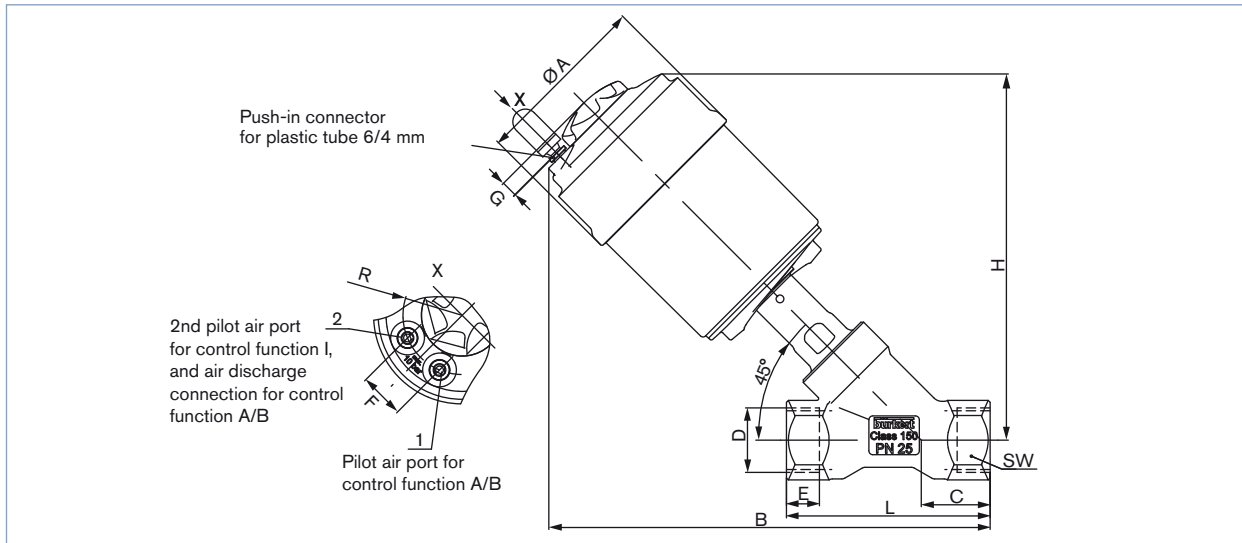

All bodies		All threaded bodies									G		NPT		Rc	
Orifice [mm]	Actuator size [mm]	Ø A	F	G	R	H	B	C	L	SW	D	E	D	E	D	E
13	50	64.5	19.8	6.1	17.15	158	192	31	85	27	G 1/2	14	NPT 1/2	13.7	RC 1/2	13.2
	70	91	23.3	8.5	30.5	173	207	31	85	27	G 1/2	14	NPT 1/2	13.7	RC 1/2	13.2
20	50	64.5	19.8	6.1	17.15	166	203	35	95	32	G 3/4	16	NPT 3/4	14	RC 3/4	14.5
	70	91	23.3	8.5	30.5	181	219	35	95	32	G 3/4	16	NPT 3/4	14	RC 3/4	14.5
25	50	64.5	19.8	6.1	17.15	174	212	35.5	105	41	G 1	18	NPT 1	16.8	RC 1	16.8
	70	91	23.3	8.5	30.5	189	228	35.5	105	41	G 1	18	NPT 1	16.8	RC 1	16.8
32	70	91	23.3	8.5	30.5	195	240	41	120	50	G 1 1/4	20	NPT 1 1/4	17.3	RC 1 1/4	19.1
	90	120	23.3	8.5	30.5	238	280	41	120	50	G 1 1/4	20	NPT 1 1/4	17.3	RC 1 1/4	19.1
40	70	91	23.3	8.5	30.5	200	243	40	130	55	G 1 1/2	22	NPT 1 1/2	17.3	RC 1 1/2	19.1
	90	120	23.3	8.5	30.5	242	283	40	130	55	G 1 1/2	22	NPT 1 1/2	17.3	RC 1 1/2	19.1
50	70	91	23.3	8.5	30.5	216	264	45	150	65	G 2	24	NPT 2	17.6	RC 2	23.4
	90	120	23.3	8.5	30.5	256	302	45	150	65	G 2	24	NPT 2	17.6	RC 2	23.4

Dimensions angle seat valve Type 2100 [mm], *continued*

Welded body

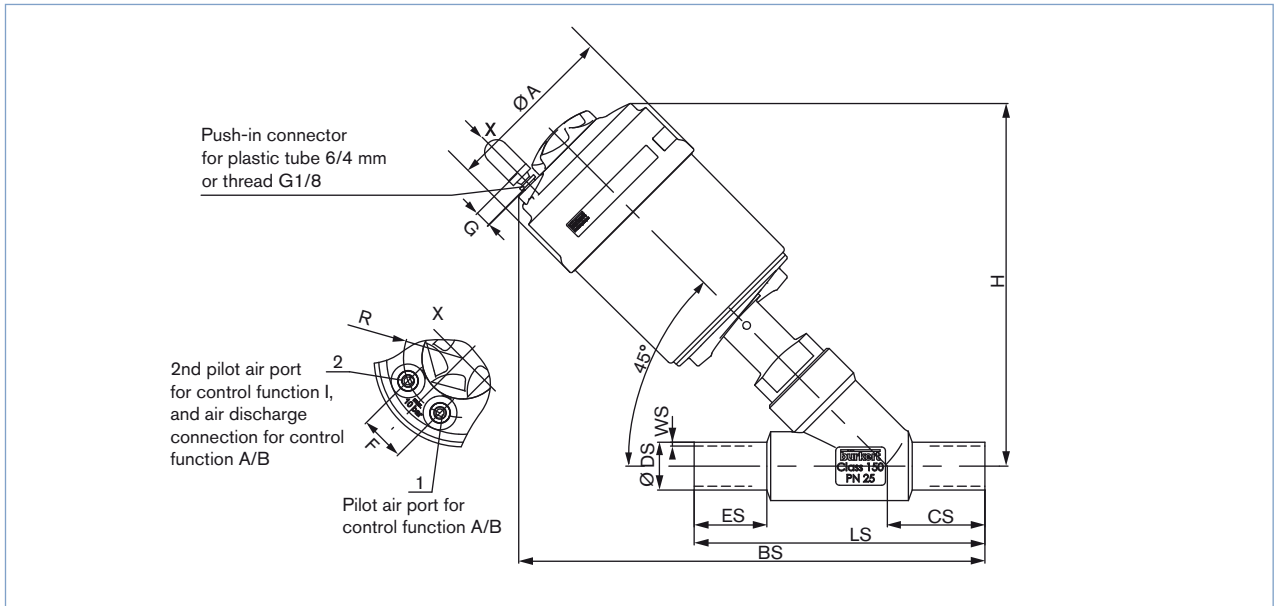

ISO 4200, DIN 11850 S2

All bodies							ISO 4200 / DIN 11850 S2			ISO 4200			DIN 11850 S2		
Orifice [mm]	Actuator size [mm]	Ø A	F	G	R	H	BS	CS	LS	ES	WS	ø DS	ES	WS	ø DS
15	50	64.5	19.8	6.1	17.15	158	195	34	100	20	1.6	21.3	20	1.5	19.0
	70	91	23.3	8.5	30.5	173	210	34	100	20	1.6	21.3	20	1.5	19.0
20	50	64.5	19.8	6.1	17.15	166	207	39	115	25	1.6	26.9	25	1.5	23.0
	70	91	23.3	8.5	30.5	181	223								
25	50	64.5	19.8	6.1	17.15	174	220	43	130	30	2	33.7	26	1.5	29.0
	70	91	23.3	8.5	30.5	189	236								
32	70	91	23.3	8.5	30.5	195	239	40	145	26	2	42.4	26	1.5	35.0
	90	120	23.3	8.5	30.5	238	279								
40	70	91	23.3	8.5	30.5	200	252	49	160	30	2	48.3	26	1.5	41.0
	90	120	23.3	8.5	30.5	242	292								
50	70	91	23.3	8.5	30.5	216	269	50	175	30	2.6	60.3	26	1.5	53.0
	90	120	23.3	8.5	30.5	256	307								

ASME BPE, BS 4825

All bodies							ASME BPE / BS 4825			ASME BPE			BS 4825		
Orifice [mm]	Actuator size [mm]	Ø A	F	G	R	H	BS	CS	LS	ES	WS	ø DS	ES	WS	ø DS
15	50	64.5	19.8	6.1	17.15	158	195	34	100	15	1.65	12.7	20	1.2	12.7
	70	91	23.3	8.5	30.5	173	210								
20	50	64.5	19.8	6.1	17.15	166	207	39	115	25	1.65	19.05	25	1.2	19.05
	70	91	23.3	8.5	30.5	181	223								
25	50	64.5	19.8	6.1	17.15	174	220	43	130	30	1.65	25.4	30	1.65	25.4
	70	91	23.3	8.5	30.5	189	236								
40	70	91	23.3	8.5	30.5	200	252	49	160	30	1.65	38.1	30	1.65	38.1
	90	120	23.3	8.5	30.5	242	292								
50	70	91	23.3	8.5	30.5	216	269	50	175	30	1.65	50.8	30	1.65	50.8
	90	120	23.3	8.5	30.5	256	307								

Dimensions angle seat valve Type 2100 [mm], *continued*

Welded body, *continued*

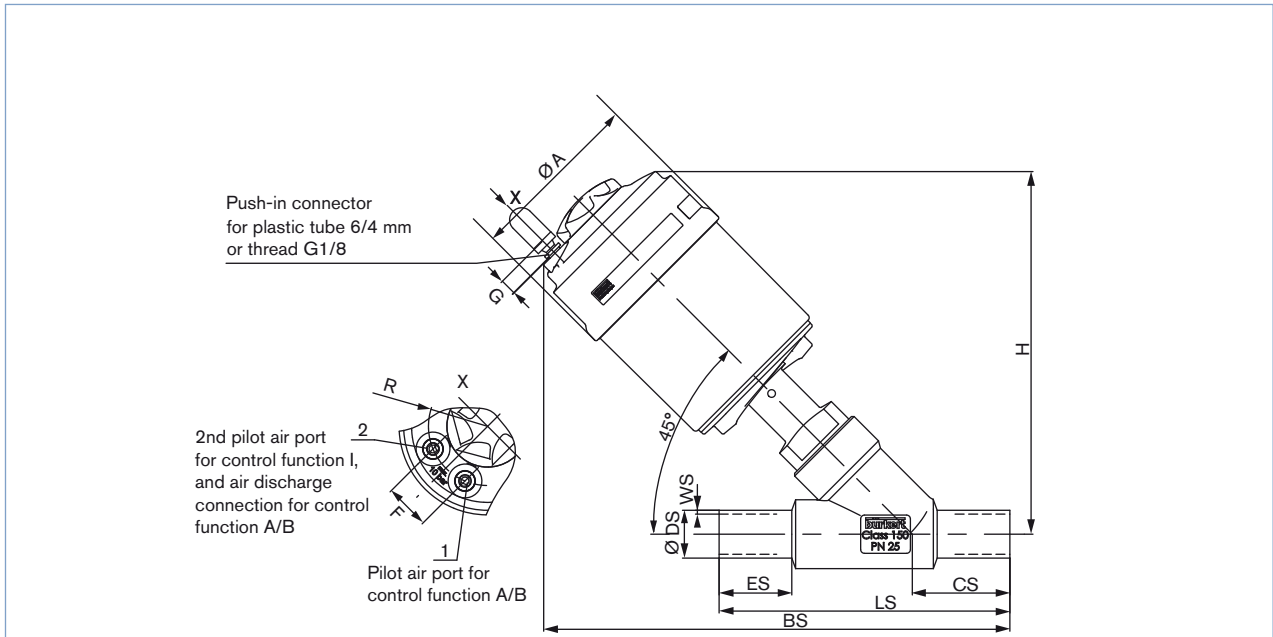

SMS 3008

All bodies							SMS 3008					
Orifice [mm]	Actuator size [mm]	Ø A	F	G	R	H	BS	CS	LS	ES	WS	ø DS
15	50	64.5	19.8	6.1	17.15	158	207	46	135	38	1	12.0
	70	91	23.3	8.5	30.5	173	222					18.0
20	50	64.5	19.8	6.1	17.15	166	220	52	145	38	1	18.0
	70	91	23.3	8.5	30.5	181	236					25.0
25	50	64.5	19.8	6.1	17.15	174	228	51	152	38	1.2	25.0
	70	91	23.3	8.5	30.5	189	244					25.0
32	50	91	23.3	8.5	30.5	195	239	40	145	26	1.2	38.0
	70	120	23.3	8.5	30.5	238	279					38.0
40	70	91	23.3	8.5	30.5	200	263	60	182	38	1.2	38.0
	90	120	23.3	8.5	30.5	242	303					38.0
50	70	91	23.3	8.5	30.5	216	283	64	210	45	1.2	51.0
	90	120	23.3	8.5	30.5	256	321					51.0

Dimensions angle seat valve Type 2100 [mm], *continued*

Clamp body

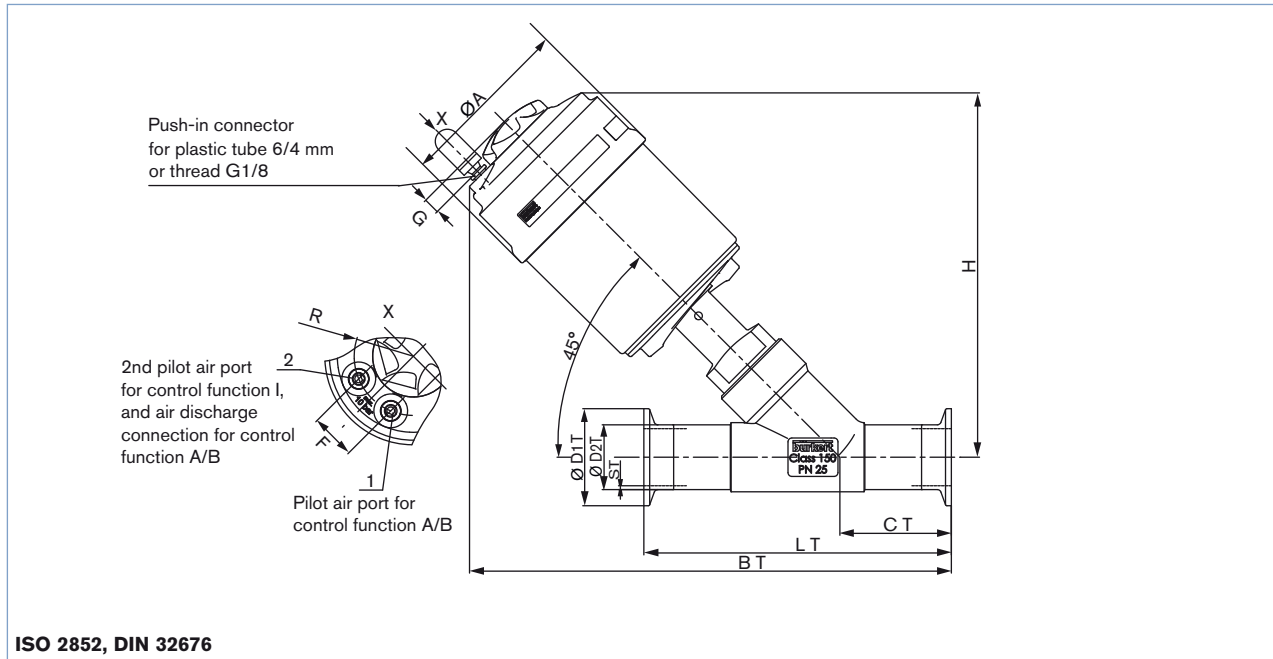

ISO 2852, DIN 32676

All bodies							ISO 2852/DIN 32676			ISO 2852			DIN 32676		
Orifice [mm]	Actuator size [mm]	Ø A	F	G	R	H	BT	CT	LT	ø D1T	ø D2T	ST	ø D1T	ø D2T	ST
15	50	64.5	19.8	6.1	17.15	158	211	49.5	130	34	21.3	1.6	34	19	1.5
	70	91	23.3	8.5	30.5	173	226								
20	50	64.5	19.8	6.1	17.15	166	225	57	150	50.5	26.9	1.6	34	23	1.5
	70	91	23.3	8.5	30.5	181	241								
25	50	64.5	19.8	6.1	17.15	174	236	58.5	160	50.5	33.7	2	50.5	29	1.5
	70	91	23.3	8.5	30.5	189	252								
32	70	91	23.3	8.5	30.5	195	257	58	180	50.5	42.4	2	50.5	35	1.5
	90	120	23.3	8.5	30.5	238	297								
40	70	91	23.3	8.5	30.5	200	273	69.5	200	64	48.3	2	50.5	41	1.5
	90	120	23.3	8.5	30.5	242	313								
50	70	91	23.3	8.5	30.5	216	297	78	230	77.5	60.3	2.6	64	53	1.5
	90	120	23.3	8.5	30.5	256	335								

BS 4825, ASME BPE

All bodies							BS 4825 / ASME BPE			BS 4825			ASME BPE		
Orifice [mm]	Actuator size [mm]	Ø A	F	G	R	H	BT	CT	LT	ø D1T	ø D2T	ST	ø D1T	ø D2T	ST
15	50	64.5	19.8	6.1	17.15	158	211	49.5	130	25.2	12.7	1.2	25	12.7	1.65
	70	91	23.3	8.5	30.5	173	226								
20	50	64.5	19.8	6.1	17.15	166	225	57	150	25.2	19.05	1.2	25	19.05	1.65
	70	91	23.3	8.5	30.5	181	241								
25	50	64.5	19.8	6.1	17.15	174	236	58.5	160	50.5	25.4	1.65	-	-	-
	70	91	23.3	8.5	30.5	189	252								
40	70	91	23.3	8.5	30.5	200	273	69.5	200	50.5	38.1	1.65	-	-	-
	90	120	23.3	8.5	30.5	242	313								
50	70	91	23.3	8.5	30.5	216	297	78	230	64	50.8	1.65	-	-	-
	90	120	23.3	8.5	30.5	256	335								

Ordering information for valve system On/Off Type 8801-YE

A valve system On/Off Type 8801-YE consists of an angle seat valve Type 2100 and a pneumatic control unit Type 8690, control head Type 8691 (for valve actuator sizes $\varnothing 70/\varnothing 90$ mm) or control head Type 8695 (for valve actuator size $\varnothing 50$ mm) (see separate datasheets).

For the configuration of further valve systems please use the "Request for quotation" on p. 22 [go to page](#)

You order two components and receive a complete assembled and certified valve.

Ordering the valve system On/Off Type 8801-YE with valve actuator sizes $\varnothing 70 / \varnothing 90$ mm

Angle seat valve Type 2100 with actuator sizes $\varnothing 70 / \varnothing 90$ mm



Control units



Type 8690



Type 8691

Angle seat valve with desired control unit



Valve system On/Off
Type 8801-YE-K
2100 + 8690



Valve system On/Off
Type 8801-YE-H
2100 + 8691

Click on the orange box "More info." below... you will come to our website for the resp. product where you can download the datasheet.

Pneumatic control unit Type 8690



More info.

The new generation of integrated controllers for combination with actuators from the process valve series Type 21xx is specially designed for the requirements of hygienic process environments. The pneumatic control unit Type 8690 combines electrical position feedback and pneumatic control for single or double-acting actuators, and is also optionally available as an intrinsically safe model to ATEX.

Main customer benefits:

- Compact design of the valve system with integrated controller meets the demands for plant washdown environments through the selection of materials, external seals and integrated control air supply to the actuator.
- Integrated pilot valve with manual actuation
- Air intake filter enhances the process valve system availability
- Simple and reliable actuator adaptations allowing additional actuators of the process valve series, Type 20xx or actuators from other manufacturers to be used

Control head Type 8691



More info.

The new generation of integrated control heads for combination with actuators from the process valve series Type 21xx is specially designed for the requirements of hygienic process environments. The intelligent control head, Type 8691, detects the valve position by means of a contact-free analog position sensor circumventing excessive wear of mechanical parts. Single or double-acting actuators are controlled via the integral pilot valve. Communication interfaces AS-Interface and DeviceNet are available as options.

Main customer benefits:

- Compact, hygienic design of the valve system with integrated controller meets the demands of plant washdown environments through the selection of materials, external seals and integrated control air supply to the actuator.
- Automatic setting of the control head at the push of a button
- Even under dirty or dark environments, a clearly visible status display due to powerful LEDs
- Monitoring and diagnosis: Process valve systems with field bus interface used in modern plant processes
- Integrated pilot valve with manual actuation
- Air intake filter enhances the process valve system availability
- Simple and reliable actuator adaptations allowing additional actuators of the process valve series, Type 20xx or actuators from other manufacturers to be used

Ordering information for valve system On/Off Type 8801-YE, *continued*

A valve system On/Off Type 8801-YE consists of an angle seat valve Type 2100 and a pneumatic control unit Type 8690, control head Type 8691 (for valve actuator sizes $\varnothing 70/\varnothing 90\text{mm}$) or control head Type 8695 (for valve actuator size $\varnothing 50\text{ mm}$) (see separate datasheets).

For the configuration of further valve systems please use the "Request for quotation" on p. 22 [go to page](#)

You order two components and receive a complete assembled and certified valve.

Ordering the valve system On/Off Type 8801-YE with valve actuator size $\varnothing 50\text{ mm}$

Angle seat valve Type 2100 with actuator size $\varnothing 50\text{ mm}$



Control unit



Type 8695

Angle seat valve with desired control unit



Valve system On/Off Type 8801-YE-M 2100 + 8695

Click on the orange box "More info." below... you will come to our website for the resp. product where you can download the datasheet.

Control head Type 8695



More info.

The new generation of integrated control heads for combination with small actuators from the process valve series Type 21xx is specially designed for the requirements of hygienic process environments. The intelligent control head, Type 8695, detects the valve position by means of a contact-free analog position sensor circumventing excessive wear of mechanical parts. Single and double-acting actuators are controlled via the integral pilot valve. An AS-Interface communication interface is available as an option.

Main customer benefits:

- Compact, hygienic design of the valve system with integrated controller meets the demands of plant washdown environments through the selection of materials, external seals and integrated control air supply to the actuator
- Automatic setting of the control head at the push of a button
- Visual status display on the control head
- Monitoring and diagnosis: Process valve systems with fieldbus interface used in modern plant processes
- Integrated pilot valve
- Simple and reliable actuator adaption

Dimensions for valve system On/Off Type 8801-YE [mm]

Dimensions valve system On/Off Type 8801-YE with pneumatic control unit Type 8690 [mm]

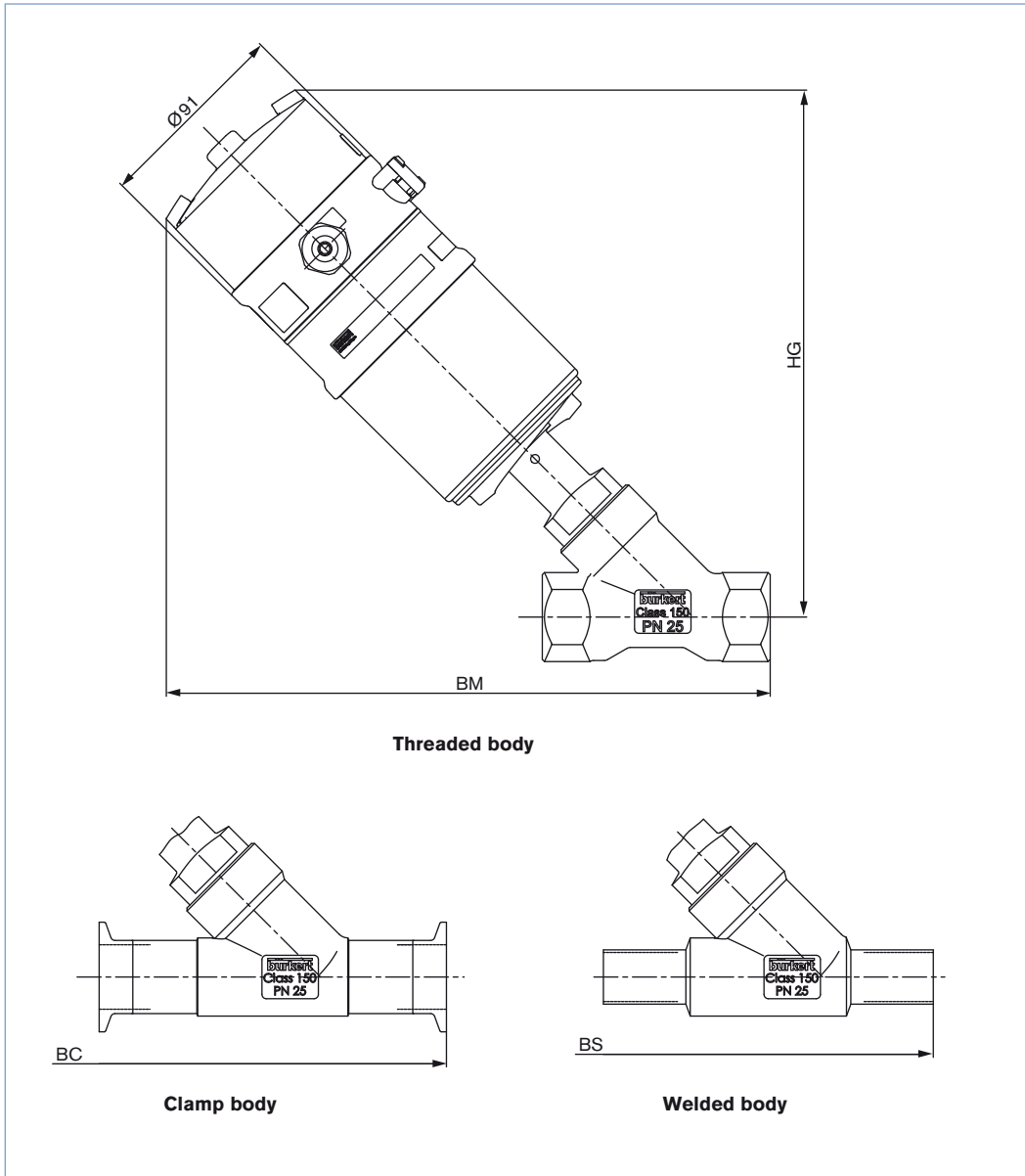

All bodies		HG	Threaded body	Welded body		Clamp body
Orifice [mm]	Actuator size [mm]		ISO 4200, DIN 11850 S2, ASME BPE	SMS 3008	ISO 2852, DIN 32676, BS 4825, ASME BPE	
			BM	BS	BS	BC
13	70	227	257	260	272	275.5
20	70	235	269	273	286	291
25	70	243	278	285.5	293.5	301
32	70	249	290	289	289	307
	90	290	330	329	329	347
40	70	254	293	302	313	322.5
	90	294	333	342	353	362.5
50	70	270	314	319	333	347
	90	308	352	357	371	385

Dimensions for valve system On/Off Type 8801-YE [mm], *continued*

Dimensions valve system On/Off Type 8801-YE with control head Type 8691 [mm]

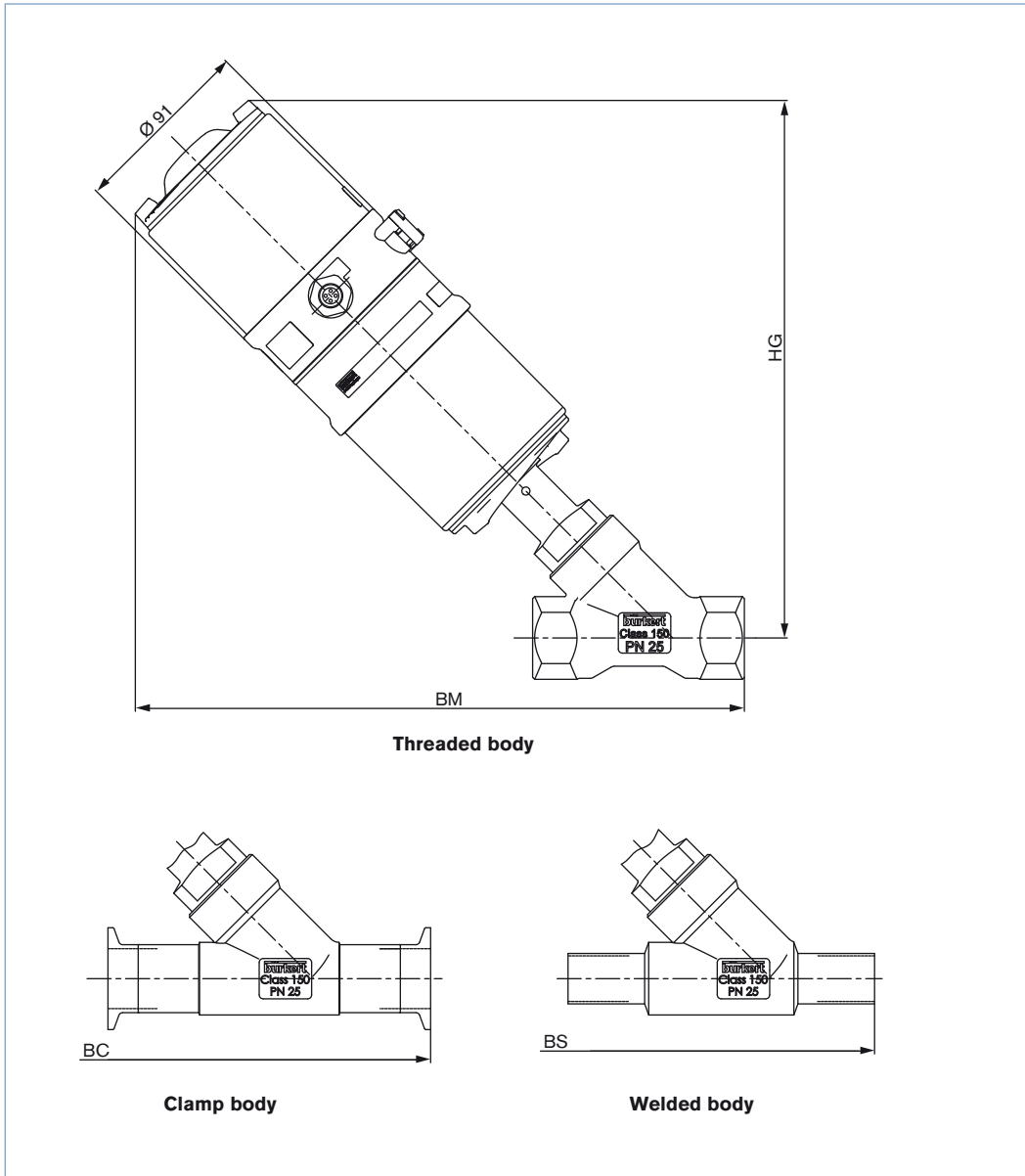

All bodies			Threaded body	Welded body		Clamp body
Orifice	Actuator size			ISO 4200, DIN 11850 S2, ASME BPE	SMS 3008	ISO 2852, DIN 32676, BS 4825, ASME BPE
[mm]	[mm]	HG	BM	BS	BS	BC
13	70	251	281	284	296	299.5
20	70	259	293	297	310	315
25	70	267	302	309.5	317.5	325
32	70	273	314	313	313	331
	90	314	354	353	353	371
40	70	278	317	326	337	346.5
	90	318	357	366	377	386.5
50	70	294	338	343	357	371
	90	332	376	381	395	409

Dimensions for valve system On/Off Type 8801-YE [mm], *continued*

Dimensions valve system On/Off Type 8801-YE with control head Type 8695 [mm]

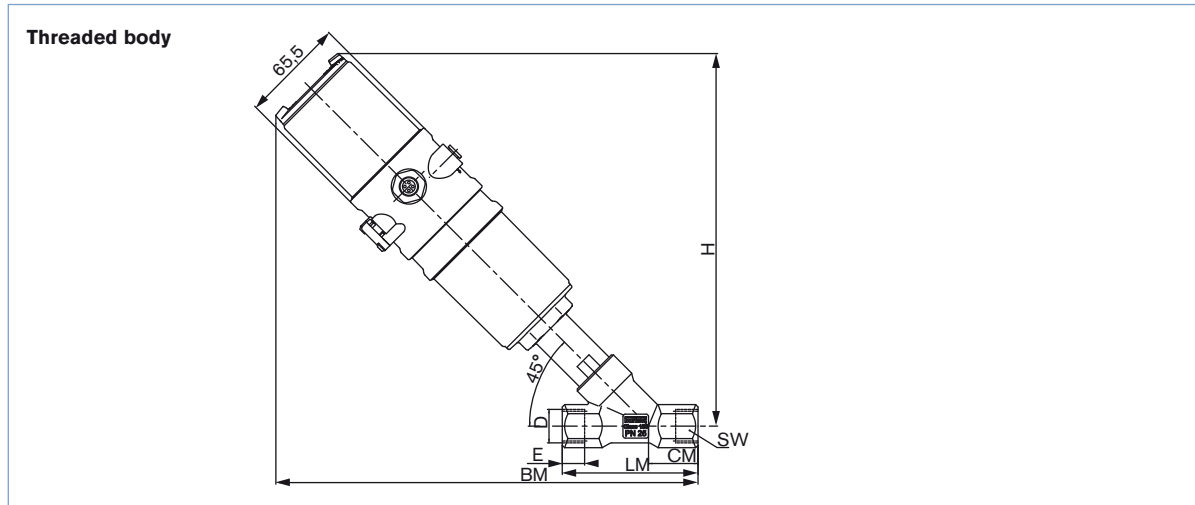

All threaded bodies							Port connection					
Orifice [mm]	Actuator size [mm]	H	BM	CM	SW	LM	G		NPT		RC	
							D	E	D	E	D	E
13	50	234	265	31	27	85	G 1/2	14	NPT 1/2	13.7	RC 1/2	13.2
			262	28	32		G 3/4	16	NPT 3/4	14	RC 3/4	14.5
20	50	242	276	35	32	95	G 3/4	16	NPT 3/4	14	RC 3/4	14.5
			272	31	41		G 1	18	NPT 1	16.8	RC 1	16.8
25	50	250	285	35.5	41	105	G 1	18	NPT 1	16.8	RC 1	16.8
			281	31.5	50		G 1 1/4	20	NPT 1 1/4	17.3	RC 1 1/4	19.1

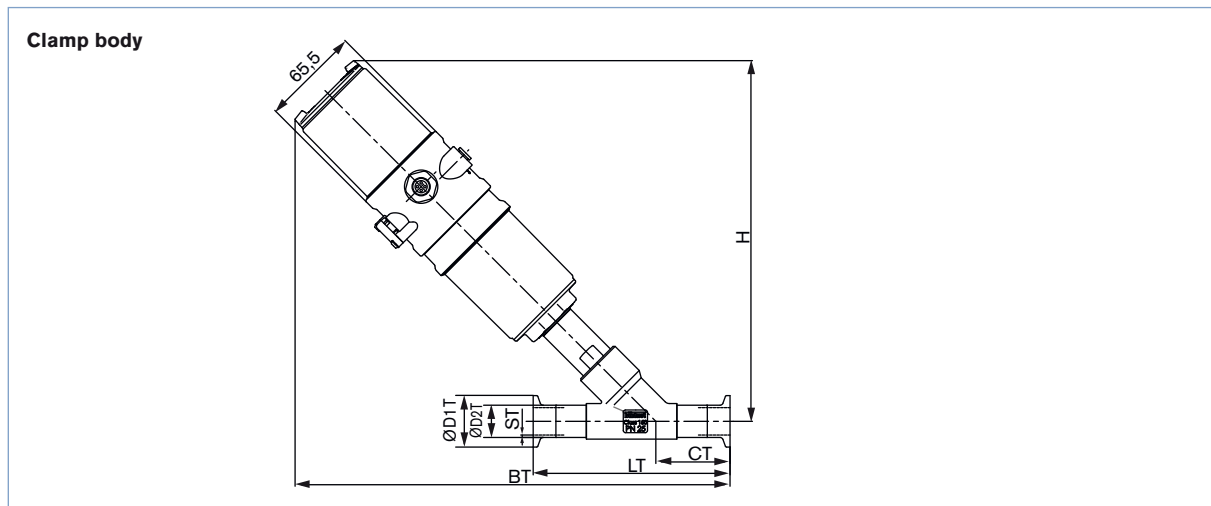

All clamp bodies						ISO 2852			DIN 32676			BS 4825			ASME BPE		
Orifice [mm]	Actuator size [mm]	H	BT	CT	LT	ØD1T	ØD2T	ST	ØD1T	ØD2T	ST	ØD1T	ØD2T	ST	ØD1T	ØD2T	ST
13	50	234	284	49.5	130	34	21.3	1.6	34	19	1.5	25.2	12.7	1.2	25	12.7	1.65
20	50	242	298	57	150	50.5	26.9	1.6	50.5	26.9	1.6	25.2	19.05	1.2	25	19.05	1.65
25	50	250	309	58.5	160	50.5	33.7	2	50.5	33.7	2	50.5	25.4	1.65	-	-	-

Dimensions for valve system On/Off Type 8801-YE [mm], *continued*

Dimensions valve system On/Off Type 8801-YE with control head Type 8695 [mm]

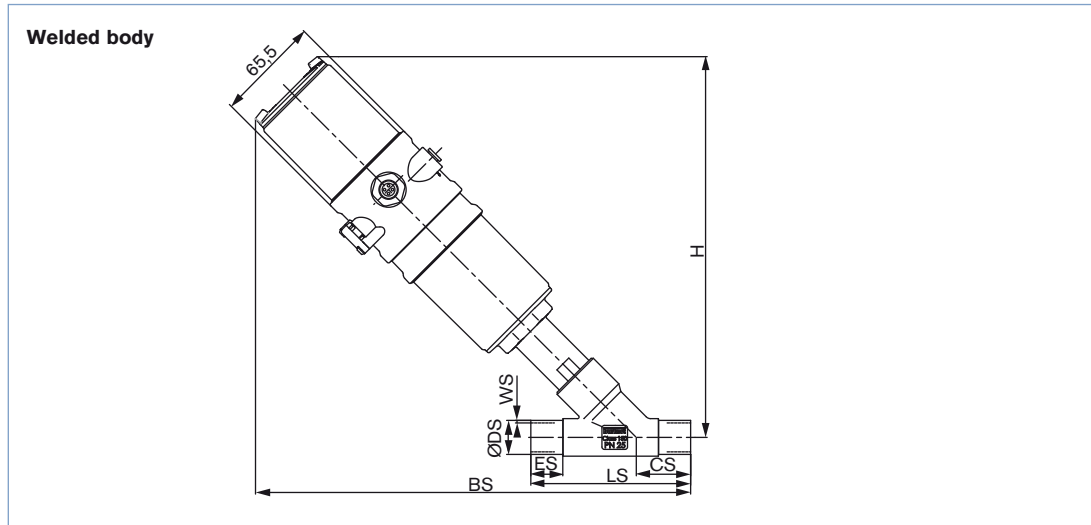

All welded bodies			ISO 4200						DIN 11850 S2					
Orifice [mm]	Actuator size [mm]	H	BS	CS	LS	ø DS	ES	WS	BS	CS	LS	ø DS	ES	WS
15	50	234	268	34	100	13.5	20	1.6	268	34	100	19	20	1.5
						17.2								
						21.3								
20	50	242	280	39	115	26.9	25	1.6	280	39	115	23	25	1.5
25	50	250	293	43	130	33.7	30	2	293	43	130	29	26	1.5

All welded bodies			SMS 3008						ASME BPE					
Orifice [mm]	Actuator size [mm]	H	BS	CS	LS	ø DS	ES	WS	BS	CS	LS	ø DS	ES	WS
15	50	234	280	46	135	12.0	38	1	268	34	100	12.7	15	1.65
20	50	242	293	52	145	18.0	38	1	280	39	115	19.05	25	1.65
25	50	250	301	51	152	25.0	38	1.2	293	43	130	25.4	30	1.65

All welded bodies			BS 4825					
Orifice [mm]	Actuator size [mm]	H	BS	CS	LS	ø DS	ES	WS
15	50	234	268	34	100	12.7	20	1.2
20	50	242	280	39	115	19.05	25	1.2
25	50	250	293	43	130	25.4	30	1.65

Note

You can fill out the fields directly in the PDF file before printing out the form.

Valve system On/Off Type 8801-YE - Request for quotation

▶ Please fill out and send to your nearest Bürkert facility* with your inquiry or order

Company	Contact person
Customer no.	Department
Address	Tel./Fax
Postcode/town	E-mail

= mandatory fields to fill out Quantity Required delivery date

Operating data

Pipe line DN PN

Pipe material

Process medium

Type of media Liquid Steam Gas

Valve features

Seal material PTFE NBR Other

Nominal pressure PN

Orifice DN

Type of connection Threaded Welded Clamp

Standard connection ISO DIN Other

Body material selection with welded connection, acc. to EN ISO 1127/ISO 4200 and DIN 11850 St. st. 1.4581 St. st. 316 L

Control function NC¹⁾ NO¹⁾ Double-acting

Pilot pressure min. max.

Please specify item no. if known:

¹⁾ NC: normally closed by spring action; NO: normally open by spring action

Control unit features

For actuator sizes 70/90 mm	For actuator sizes 70/90 mm	For actuator size 50 mm
<input type="checkbox"/> Pneumatic Control Unit Type 8690	<input type="checkbox"/> Control Head Type 8691	<input type="checkbox"/> Control Head Type 8695
Pneumatic function <input type="checkbox"/> Single-acting <input type="checkbox"/> Double-acting Position feedback <input type="checkbox"/> 1x inductive <input type="checkbox"/> 2x inductive <input type="checkbox"/> 1x inductive (NAMUR) <input type="checkbox"/> 2x inductive (NAMUR) <input type="checkbox"/> 1x mechanical <input type="checkbox"/> 2x mechanical Supply voltage <input type="checkbox"/> 24 V / DC (ATEX Zone 2/22) <input type="checkbox"/> Ex ia IIC T6 (ATEX Zone 1) Pilot air ports <input type="checkbox"/> Push-in connector ø 6/4 mm <input type="checkbox"/> Thread G 1/8" Please specify item no. if known: <input type="text"/>	Pneumatic function <input type="checkbox"/> Single-acting <input type="checkbox"/> Double-acting Pilot air ports <input type="checkbox"/> Push-in connector ø 6/4 mm <input type="checkbox"/> Thread G 1/8" Communication <input type="checkbox"/> ASI <input type="checkbox"/> Multipol M12 <input type="checkbox"/> Flat cable clip, 1 m cable <input type="checkbox"/> DeviceNet Please specify item no. if known: <input type="text"/>	Pneumatic function <input type="checkbox"/> Single-acting <input type="checkbox"/> Double-acting Pilot air ports <input type="checkbox"/> Push-in connector ø 6/4 mm <input type="checkbox"/> Thread G 1/8" Communication <input type="checkbox"/> ASI Please specify item no. if known: <input type="text"/>

Comments

* To find your nearest Bürkert facility, click on the orange box → www.burkert.com

In case of special application conditions, please consult for advice.

Subject to alteration.
© Christian Bürkert GmbH & Co. KG

0811/3_EU-en_00895001

DTS 1000095355 EN Version: D Status: RL (released | freigegeben | validé) printed: 19.11.2008